

ACE-850AP 500 W PS/2 Type ATX Power Supply



PFC

New version 20+4-pin power supply



1
Industrial
Computing
Solutions

2
Embedded
Computing
Solutions

3
RISC-Based
Embedded
Solutions

4
Industrial
Data
Collector/
Server
Solutions

5
Industrial
Data
Collection

6
I/O
Communication
Solutions

7
Panel
Solutions

8
Power Supply/
Network
Communication/
Peripherals

Features

1. High efficiency
2. 20+4-pin ATX power connector
3. Short circuit protection on all outputs
4. Extra P10 (+5 V) connector for most high-power requirement
5. Built-in ball bearing cooling fan
6. Total +12 V output up to 36 A

Power Connector +12 V

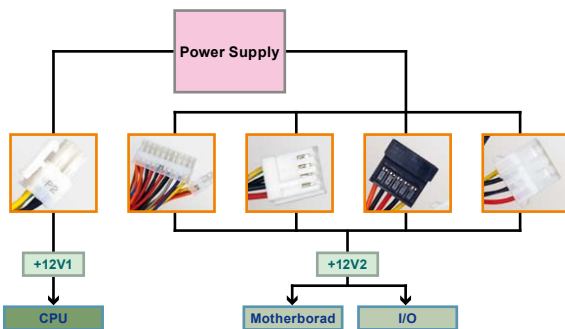

Dual 12 V Separate Lines:

As processors become faster and more highly integrated, more current is required. To reduce power distribution loss, board manufacturers are moving from 5V to 12V power distribution. System components that use 12V are continuing to increase in power.

Version 2.0 of Intel's ATX12V Power Supply Design Guide began recommending dual 12V lines for PSUs that can deliver more than 18A at 12V. Why? To abide by safety requirements of UL and EM 60950, which stipulates not more than 240VA on any wires or exposed traces. Intel's PSU Guide calls for a current limiter that keeps current to under 20A on each of the 12V rails: 12V x 20A = 240VA.

What is the safety reason for this 240VA maximum? It's the maximum recommended for an electronic device that a consumer will have reasonable likelihood of access.

The +12V1 (1st. +12V rails) supply the AUX12V (2x12V) 4-pin plug, which feeds only the CPUs.

The +12V2 (2nd. +12V rail) supplies the 24-pin ATX main power connector & 4-pin Peripheral Power connectors, which feeds for the Mother Board & IO devices dedicated +12V rails for Processors

PICMG1.0 Form Factor Backplane



20+4-pin ATX power connector

PICMG 1.3 form factor Backplane PE-10S/6S



Specifications

Input voltage	90 ~ 264 VAC full range				
Input frequency	47 ~ 63 Hz				
Input current	10 A (RMS) for 115 VAC				
	5 A (RMS) for 230 VAC				
Inrush current	80 A max. for 115 VAC				
	120 A max. for 230 VAC				
Output voltage	Voltage	Min. load	Max. load	Ripple & Noise	
	+3.3 V	0.4 A min	27 A	50 mV	
	+5 V	3 A min	29 A	50 mV	
	+12 V1	1 A min	18 A	120 mV	
	+12 V2	1 A min	18 A	120 mV	
	-5 V		0.3 A	120 mV	
	-12 V		0.8 A	120 mV	
	+5 Vsb		2 A	50 mV	
	+3.3 V & +5 V total output not exceed 150 W				
	+3.3 V & +5 V & +12 V total output not exceed 478 W				
Over voltage protection	+5 V	5.6 V ~ 6.5 V			
	+3.3 V	3.8 V ~ 4.5 V			
	+12 V	13 V ~ 14.5 V			
Short circuit protection	+3.3 V, +5 V, +12 V short circuit all the output				
Hold up time	18 ms min.				
MTBF	100,000 hours				
Operating temperature	0°C ~ 50°C				
Storage temperature	-20°C ~ 80°C				
Efficiency	63%				
Dimensions	140 x 150 x 86 mm				
Outline connector	20+4-pin ATX x1, 4-pin 12 V CPU x1, HDD/CDROM x9, FDD x2, SATA x2, extra +5 V(P10) x1				

Ordering Information

Part No.	Description
ACE-850AP-RS-24	20+4-pin 500 W ATX power supply with PFC function